



ANGLE GRINDER Ø115MM, 230V 750W

MODEL NO: **SG115E.V2, SG115EHV.V2**

Thank you for purchasing a Sealey product. Manufactured to a high standard, this product will, if used according to these instructions, and properly maintained, give you years of trouble free performance.

IMPORTANT: PLEASE READ THESE INSTRUCTIONS CAREFULLY. NOTE THE SAFE OPERATIONAL REQUIREMENTS, WARNINGS & CAUTIONS. USE THE PRODUCT CORRECTLY AND WITH CARE FOR THE PURPOSE FOR WHICH IT IS INTENDED. FAILURE TO DO SO MAY CAUSE DAMAGE AND/OR PERSONAL INJURY AND WILL INVALIDATE THE WARRANTY. KEEP THESE INSTRUCTIONS SAFE FOR FUTURE USE.



Refer to instructions



Wear eye protection



Wear protective gloves



Wear safety footwear



Wear protective clothing



Wear ear protection



Wear a mask



Wear respiratory protection (fumes)

1. SAFETY

WARNING! Read all safety warnings, instructions, illustrations and specifications provided with this power tool. Failure to follow all instructions listed below may result in electric shock, fire and/or serious injury. Save all warning and instructions for future reference.

1.1. WORK AREA SAFETY

- ✓ Keep work area clean and well lit. Cluttered or dark areas invite accidents.
- ✗ **DO NOT** operate power tools in explosive atmospheres, such as in the presence of flammable materials, liquids, gases or dust. Power tools create sparks which may ignite the dust or fumes.
- ✓ Keep children and bystanders away whilst operating a power tool. Distractions can cause you to lose control.
- ✓ Anyone entering the work area must wear personal protective equipment. Fragments of workpiece or of a broken accessory may fly away and cause injury beyond immediate area of operation.

1.2. ELECTRICAL SAFETY

- WARNING!** It is the user's responsibility to check the following:
- ✓ Check all electrical equipment and appliances to ensure that they are safe before using. Inspect power supply leads, plugs and all electrical connections for wear and damage. Sealey recommend that an RCD (Residual Current Device) is used with all electrical products.
Electrical safety information. It is important that the following information is read and understood:
 - ✓ Ensure that the insulation on all cables and on the appliance is safe before connecting it to the power supply.
 - ✓ Regularly inspect power supply cables and plugs for wear or damage and check all connections to ensure that they are secure.
Important: Ensure that the voltage rating on the appliance suits the power supply to be used and that the plug is fitted with the correct fuse.
- ✗ **DO NOT** pull or carry the appliance by the power cable.
- ✗ **DO NOT** pull the plug from the socket by the cable.
- ✗ **DO NOT** use worn or damaged cables, plugs or connectors. Ensure that any faulty item is repaired or is replaced immediately by a qualified electrician.
- ✗ **DO NOT** expose power tools to rain or wet conditions. Water entering a power tool will increase the risk of electric shock.
- ✗ **DO NOT** abuse the cord. Never use the cord for carrying, pulling, or unplugging the power tool.
- ✓ Keep cord away from the heat, oil, sharp edges or moving parts. Damaged or entangled cords increase the risk of electric shock.
- ✓ When operating a power tool outdoors, use an extension cord suitable for outdoor use. Use of a cord suitable for outdoor use reduces the risk of electric shock.
- ✓ If operating a power tool in a damp location is unavoidable, use a residual current device (RCD) protected supply. Use of an RCD reduces the risk of electric shock. If the cable or plug is damaged during use, switch off the electricity supply and remove from use.
- ✓ If the supply cord of this power tool is damaged, it must be replaced by a specially prepared supply cord available from the manufacturer.
Ensure that repairs are carried out by a qualified electrician.
- ✓ Power tool plugs must match the outlet. Never modify the plug in any way. Do not use any adaptor plugs with earthed (grounded) power tools. Unmodified plugs and matching outlets will reduce risk of electric shock.
- ✓ Avoid body contact with earthed or grounded surfaces, such as pipes, radiators, ranges, and refrigerators. There is an increased risk of electric shock if your body is earthed or grounded.
- ✓ Hold the power tool by insulated gripping surfaces only, when performing an operation where the cutting accessory may contact hidden wiring or its own cord. Cutting accessory contacting a "live" wire may make exposed metal parts of the power tool "live" and could give the operator an electric shock.
- ✓ Position the cord clear of the spinning accessory. If you lose control, the cord may be cut or snagged, and your hand or arm may be pulled into the spinning accessory.

1.3. PERSONAL SAFETY

- ✓ Stay alert, watch what you are doing and use common sense when operating a power tool.
- ✗ **DO NOT** use a power tool whilst you are tired or under the influence of drugs, alcohol, or medication.
- WARNING!** Lapse in concentration whilst operating power tools may result in serious injury.
- ✓ Use personal protective equipment. Always wear eye protection. Protective equipment such as dust mask, non-skid safety shoes, hard hat or hearing protection use for appropriate conditions will reduce personal injuries.
- ✓ Prevent unintentional starting. Ensure the switch is in the off-position before connecting to power source and/or battery pack, picking up or carrying the tool. Carrying power tools with your fingers on the switch or energising power tools that have the switch on invites accidents.

- ✓ Remove any adjusting key or wrench before turning the power tool on. A wrench or a key left attached to a rotating part of the power tool may result in personal injury.
- ✗ **DO NOT** overreach. Keep proper footing and balance at all times. This enables better control of the power tool.
- ✗ **DO NOT** wear loose clothing or jewellery. Keep your hair, clothing and gloves away from moving parts. Loose clothes, jewellery or long hair can be caught in moving parts.
- ✓ If devices are provided for the connection of dust extraction and collection facilities, ensure these are connected and properly used.
- ✗ Never lay the power tool down until the accessory has come to a complete stop. The spinning accessory may grab the surface and pull the power tool out of your control.
- ✗ **DO NOT** run the power tool while carrying it at your side. Accidental contact with the spinning accessory could snag your clothing, pulling the accessory into your body.
- **WARNING! DO NOT** use accessories that require liquid coolants. Using water/liquid coolants may result in electrocution or shock.
- 1.4. POWER TOOL USE AND CARE**
- ✗ **DO NOT** force the power tool.
- ✓ Use the correct power tool for your application. The correct tool will do the job better and safer at the rate for which it was designed.
- ✗ **DO NOT** use the power tool if the switch does not turn it on and off. Any power tool that cannot be controlled with the switch is dangerous and must be repaired.
- ✓ Disconnect the plug from the power source and/or the battery pack from the power tool before making any adjustments, changing accessories, or storing power tools. Such preventive safety measures reduce the risk of starting the power tool accidentally.
- ✓ Store idle power tools out of the reach of children and **DO NOT** allow persons unfamiliar with these power tools or these instructions to operate the power tool.
- **WARNING!** Power tools are dangerous in the hands of untrained users.
- ✓ Maintain power tools. Check for misalignment or binding of the moving parts, breakage of parts and any other condition that may affect the power tool's operation. If damaged, have the power tool repaired before use. Many accidents are caused by poorly maintained power tools.
- ✓ Keep cutting tools sharp and clean. Properly maintained cutting tools with sharp cutting edges are less likely to bind and are easier to control.
- ✓ Use the power tool, accessories, and tool bits etc, in accordance with these instructions, taking into account the working conditions and the work to be performed. Use of the power tool for operations different from those intended could result in a hazardous situation.
- ✓ This power tool is intended to function as a grinder. Read all safety warnings, instructions, illustrations and specifications provided with this power tool. Failure to follow all instructions listed below may result in electric shock, fire and/or serious injury.
- ✓ Operations such as sanding, wire brushing, polishing or cutting-off are not recommended to be performed with this power tool.
- ✓ Operations for which the power tool was not designed may create a hazard and cause personal injury.
- ✗ **DO NOT** use accessories which are not specifically designed and recommended by the tool manufacturer. Just because the accessory can be attached to your power tool, it does not assure safe operation.
- ✓ The rated speed of the accessory must be at least equal to the maximum speed marked on the power tool. Accessories running faster than their rated speed can break and fly apart.
- ✓ The outside diameter and the thickness of your accessory must be within the capacity rating of your power tool. Incorrectly sized accessories cannot be adequately guarded or controlled.
- ✓ Threaded mounting of accessories must match the grinder spindle thread. For accessories mounted by flanges, the arbour hole of the accessory must fit the locating diameter of the flange. Accessories that **DO NOT** match the mounting hardware of the power tool will run out of balance, vibrate excessively, and may cause loss of control.
- ✗ **DO NOT** use a damaged accessory. Before each use inspect the accessory such as abrasive wheels for chips and cracks, backing pad for cracks, tear or excess wear, wire brush for loose or cracked wires. If power tool or accessory is dropped, inspect for damage or install an undamaged accessory. After inspecting and installing an accessory, position yourself and bystanders away from the plane of the rotating accessory and run the power tool at maximum no-load speed for one minute. Damaged accessories will normally break apart during this test time.
- ✓ Wear personal protective equipment. Depending on application, use face shield, safety goggles or safety glasses. As appropriate, wear dust mask, hearing protectors, gloves and workshop apron capable of stopping small abrasive or workpiece fragments. The eye protection must be capable of stopping flying debris generated by various operations. The dust mask or respirator must be capable of filtering particles generated by your operation. Prolonged exposure to high intensity noise may cause hearing loss.
- 1.5. SERVICE**
- ✓ Have your power tool serviced by a qualified repair person using only identical replacement parts. This will ensure that the safety of the power tool is maintained.
- ✓ Regularly clean the power tool's air vents. The motor's fan will draw the dust inside the housing and excessive accumulation of powdered metal may cause electrical hazards.
- 1.6. HAND ARM VIBRATION**
- **WARNING!** This tool may cause Hand Arm Vibration Syndrome if its use is not managed adequately.
- ✓ This tool is subject to the vibration testing section of the Machinery Directive 2006/42/EC.
- ✓ This tool is to be operated in accordance with these instructions.
NOTE: The application of the tool to a sole specialist task may produce a different average vibration emission. We recommend that a specific evaluation of the vibration emission is conducted prior to commencing with a specialist task. A health and safety assessment by the user (or employer) will need to be carried out to determine the suitable duration of use for each tool. Stated Vibration Emission values are type-test values and are intended to be typical. Whilst in use, the actual value will vary considerably from and depend on many factors, including the operator, the task and the inserted tool or consumable. The state of maintenance of the tool itself is also an important factor, a poorly maintained tool will also increase the risk of Hand Arm Vibration Syndrome.
- 1.6.1. HEALTH SURVEILLANCE**
We recommend a program of health surveillance to detect early symptoms of vibration injury so that management procedures can be modified accordingly.
- 1.6.2. PERSONAL PROTECTIVE EQUIPMENT**
We are not aware of any personal protective equipment (PPE) that provides protection against vibration injury that may result from the uncontrolled use of this tool. We recommend a sufficient supply of clothing (including gloves) to enable the operator to remain warm and dry and maintain good blood circulation in fingers etc. Please note that the most effective protection is prevention, please refer to the correct Use and Maintenance section in these instructions.

Guidance relating to the management of hand arm vibration can be found on the HSC website www.hse.gov.uk - Hand-Arm Vibration at Work.

1.7. GRINDING AND ABRASIVE CUTTING-OFF OPERATIONS

- 1.7.1. Use only wheel types that are recommended for your power tool and the specific guard designed for the selected wheel. Wheels for which the power tool was not designed cannot be adequately guarded and are unsafe.
- 1.7.2. The grinding surface of centre depressed wheels must be mounted below the plane of the guard lip. An improperly mounted wheel that projects through the plane of the guard lip cannot be adequately protected.
- 1.7.3. The guard must be securely attached to the power tool and positioned for maximum safety, so the least amount of wheel is exposed towards the operator. The guard helps to protect the operator from broken wheel fragments, accidental contact with wheel and sparks that could ignite clothing.
- 1.7.4. Wheels must be used only for recommended applications. For example: do not grind with the side of cut-off wheel. Abrasive cut-off wheels are intended for peripheral grinding. Side forces applied to these wheels may cause them to shatter.
- 1.7.5. Always use undamaged wheel flanges that are of correct size and shape for your selected wheel. Proper wheel flanges support the wheel thus reducing the possibility of wheel breakage. Flanges for cut-off wheels may be different from grinding wheel flanges.
- ✗ **DO NOT** use worn down wheels from larger power tools. A wheel intended for larger power tool is not suitable for the higher speed of a smaller tool and may break.

1.8. INFORMATION

- 1.8.1. The declared vibration total value(s) and the declared noise emission value(s) have been measured in accordance with a standard test method and may be used for comparing one tool with another. The declared vibration total values and the declared noise emission values may also be used in a preliminary assessment of exposure.
- **WARNING!** The vibration and noise emissions during actual use of the power tool can differ from the declared values depending on the ways in which the tool is used, especially what kind of workpiece is processed. The need to identify safety measures to protect the operator that are based on an estimation of exposure in the actual condition of use.

2. INTRODUCTION

Suitable for a variety of trade applications. Features heavy-duty alloy bevel gear head with spindle lock for fast loading/unloading of discs. Vibration reducing double injection composite body with rubber coating for added comfort. Powerful 750W heavy-duty motor produces 11000rpm (no-load speed). Built-in LED power indicator. Supplied with side handle and spanner. Fitted with 1.8m of power cable and 3-pin plug.

3. SPECIFICATION

Models:	SG115E.V2 SG115EHV.V2
Disc Size:	Ø115mm
Fuse Rating:	13A
Motor Power:	750W
Nett Weight:	1.7kg
Noise Power/Pressure:	97dB(A)/86dB(A)
No-Load Speed:	11000rpm
Plug Type:	3-Pin
Power Supply Cable Length:	1.8m
Spindle Size:	M14 x 2mm
Supply:	230V~50Hz
Vibration/Uncertainty:	9.554 m/s ² /1.5 m/s ²

4. FEATURES

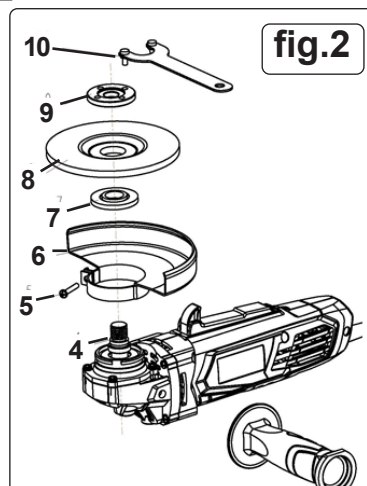
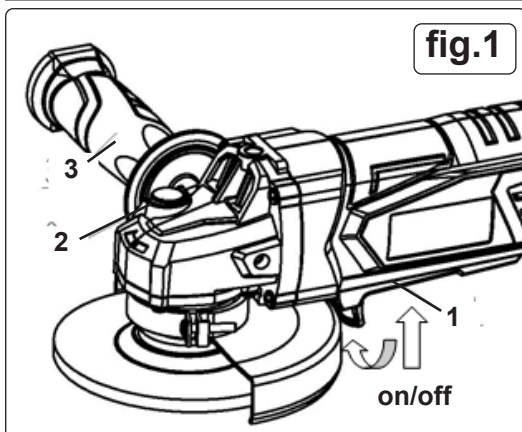

5. ASSEMBLY

- ❑ **WARNING!** When adjusting the guard, replacing a grinding or cutting disc or carrying out any other maintenance including cleaning of the tool, ensure the tool is not plugged into mains supply.
- 5.1. MOUNTING AND REMOVING THE GUARD (FIG.2)**
 - 5.1.1. First remove the grinding wheel as described below.
 - 5.1.2. Place the guard (6) on the machine as shown.
 - 5.1.3. Tighten screw (5) firmly.
 - 5.1.4. To remove the guard, proceed in reverse order.
- ❑ **WARNING!** Never use the machine without the guard in place.
- 5.2. MOUNTING AND REMOVING A GRINDING WHEEL (FIG.2 and diagrams below)**
 - 5.2.1. Place the machine on a flat surface, guard up.
 - 5.2.2. Fit the spacer (7) onto the spindle (4).
 - 5.2.3. Place the grinding wheel (8) on the spacer.
 - 5.2.4. Screw the tension nut (9) onto the spindle.
 - 5.2.5. Press the lock knob (2) and firmly tighten the tension nut (9) using the spanner (10) supplied.
 - 5.2.6. Release the lock knob.
 - 5.2.7. To remove the grinding wheel, proceed in reverse order.
- 5.3. MOUNTING AND REMOVING THE SIDE HANDLE**
 - 5.3.1. Tighten the side handle (3) in one of the three mounting holes.

6. OPERATION

- 6.1. SWITCHING ON AND OFF (FIG.3)**
 - 6.1.1. Connect to mains supply.
 - 6.1.2. ON: Move the trigger release forwards, this will allow the long section of the trigger to be squeezed and grinder will switch on.
 - 6.1.3. OFF: Release long section of the trigger.
- ❑ **NOTE:** The LED light will illuminate green when connected to a power supply.
- ❑ **WARNING!** Ensure grinder is unplugged from the mains power supply before changing accessories.
- 6.2. PREPARATION**
 - 6.2.1. Attach grinding/cutting disc according to section 6.2 and diagrams alongside.
 - 6.2.2. Position the handle grip conveniently for the task.
 - 6.2.3. Ensure the disc safety guard is correctly positioned and securely fitted.
 - 6.2.4. Plug grinder into the mains power supply.
- ❑ **WARNING!** When the grinder first starts it will kick to the right. You must ensure, therefore, that the tool is securely gripped in both hands. Especially important is the position you choose for the side handle in order to maintain stability.
- ❑ **WARNING!** Before use, ensure that you are wearing approved safety goggles, ear defenders, appropriate dust mask if dust will be generated and safety gloves, and that all other safety instructions in Section 1 are followed carefully.
- 6.3. GRINDING**
 - 6.3.1. The key to effective operating is controlling the pressure and surface contact between the disc and the work piece.
 - ❑ **WARNING! DO NOT** switch the grinder on whilst the disc is in contact with the work piece. Bring the rotating disc to the work piece.
 - 6.3.2. Allow the disc to reach full speed before starting to grind.
 - 6.3.3. Grind flat surfaces at an angle of between 10° to 20° to the work piece. Too great an angle will cause a concentration of pressure in one small area resulting in gouging or burning of the surface.
 - 6.3.4. When grinding is complete allow the work piece to cool. **DO NOT** touch the hot surface.
 - 6.3.5. Unplug the grinder from the mains power supply, clean and store in a safe, dry, childproof area.

7. GRINDING DISCS

- ❑ **WARNING! DO NOT USE DISCS THAT ARE DAMAGED, OR SUSPECTED TO BE DAMAGED.**
- 7.1. Before using a grinding/cutting disc ensure that there are no fissures or cracks. Once mounted on the grinder, test the disc before use by facing the grinder in a safe direction (point away from yourself, others and vulnerable items) and run for a short time.
- ▲ **DANGER!** Use of damaged discs is dangerous and may cause personal injury.
- 7.2. Grinding and cutting discs used in association with this machine shall be of an adequate speed rating and be suitable for the job in hand. Only persons holding a grinding wheel certificate are authorised to change grinding discs. Ensure that the speed rating on the disc is equal to, or higher than, that of the grinder.

8. MAINTENANCE

- ❑ **WARNING!** Always unplug the tool before performing maintenance.
- 8.1. Have your power tool serviced by a qualified repair person using only identical replacement parts. This will ensure that the safety of the power tool is maintained.
- 8.2. CLEANING**
 - ❑ **WARNING:** Always wear protective equipment including eye protection and gloves when cleaning this tool.
 - 8.2.1. Keep your tool clean at all times. Dirt and dust will cause internal parts to wear quickly, and shorten the device's service life.
 - 8.2.2. Clean the body of your machine with a soft brush, or dry cloth. If available, use clean, dry, compressed air to blow through the ventilation holes (where applicable).

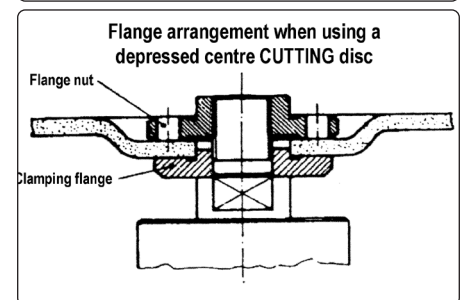
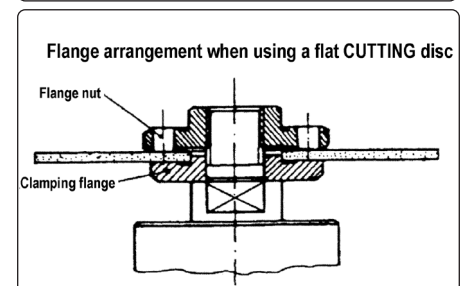
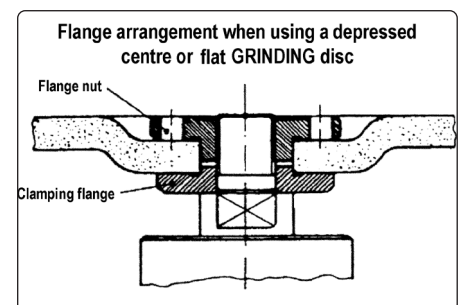

- 8.2.3. Never use caustic agents to clean plastic parts. If dry cleaning is not sufficient, a mild detergent on a damp cloth is recommended.
- 8.2.4. Water must never come into contact with the tool. Ensure the tool is thoroughly dry before using it.

8.3. STORAGE

- 8.3.1. Store this tool carefully in a secure, dry place out of the reach of children.

WARNING! – Risk of Hand Arm Vibration Injury.

This tool may cause Hand Arm Vibration Syndrome if its use is not managed adequately.

This tool is subject to the vibration testing section of the Machinery Directive 2006/42/EC.

This tool is to be operated in accordance with these instructions.

Measured vibration emission value (a): 9.554 m/s²

Uncertainty value (k): 1.5 m/s²

Please note that the application of the tool to a sole specialist task may produce a different average vibration emission. We

recommend that a specific evaluation of the vibration emission is conducted prior to commencing with a specialist task.

A health and safety assessment by the user (or employer) will need to be carried out to determine the suitable duration of use for each tool.

NB: Stated Vibration Emission values are type-test values and are intended to be typical.

Whilst in use, the actual value will vary considerably from and depend on many factors. Such factors include; the operator, the task and the inserted tool or consumable.

NB: ensure that the length of leader hoses is sufficient to allow unrestricted use, as this also helps to reduce vibration.

The state of maintenance of the tool itself is also an important factor, a poorly maintained tool will also increase the risk of Hand Arm Vibration Syndrome.

Health surveillance

We recommend a program of health surveillance to detect early symptoms of vibration injury so that management procedures can be modified accordingly.

Personal protective equipment.

We are not aware of any personal protective equipment (PPE) that provides protection against vibration injury that may result from the uncontrolled use of this tool. We recommend a sufficient supply of clothing (including gloves) to enable the operator to remain warm and dry and maintain good blood circulation in fingers etc. Please note that the most effective protection is prevention, please refer to the Correct Use and Maintenance section in these instructions. Guidance relating to the management of hand arm vibration can be found on the HSC website www.hse.gov.uk - Hand-Arm Vibration at Work

The declared vibration total value(s) and the declared noise emission value(s) have been measured in accordance with a standard test method and may be used for comparing one tool with another. The declared vibration total values and the declared noise emission values may also be used in a preliminary assessment of exposure

The vibration and noise emissions during actual use of the power tool can differ from the declared values depending on the ways in which the tool is used, especially what kind of workpiece is processed The need to identify safety measures to protect the operator that are based on an estimation of exposure in the actual condition of use.

The declared vibration total value(s) and the declared noise emission value(s) have been measured in accordance with a standard test method and may be used for comparing one tool with another. The declared vibration total values and the declared noise emission values may also be used in a preliminary assessment of exposure

The vibration and noise emissions during actual use of the power tool can differ from the declared values depending on the ways in which the tool is used, especially what kind of workpiece is processed The need to identify safety measures to protect the operator that are based on an estimation of exposure in the actual condition of use.



WEEE REGULATIONS

Dispose of this product at the end of its working life in compliance with the EU Directive on Waste Electrical and Electronic Equipment (WEEE). When the product is no longer required, it must be disposed of in an environmentally protective way. Contact your local solid waste authority for recycling information.



ENVIRONMENT PROTECTION

Recycle unwanted materials instead of disposing of them as waste. All tools, accessories and packaging should be sorted, taken to a recycling centre and disposed of in a manner which is compatible with the environment. When the product becomes completely unserviceable and requires disposal, drain any fluids (if applicable) into approved containers and dispose of the product and fluids according to local regulations.



Note: It is our policy to continually improve products and as such we reserve the right to alter data, specifications and component parts without prior notice. Please note that other versions of this product are available. If you require documentation for alternative versions, please email or call our technical team on technical@sealey.co.uk or 01284 757505.

Important: No Liability is accepted for incorrect use of this product.

Warranty: Guarantee is 12 months from purchase date, proof of which is required for any claim..

Jack Sealey Ltd t/a Sealey Group, Kempson Way, Suffolk Business Park, Bury St Edmunds, Suffolk, IP32 7AR UK
Jack Sealey (EU) Ltd t/a Sealey Group, Farney Street, Carrickmacross, Co. Monaghan, A81 PK68 Ireland
Tel: 01284 757500 • Email: sales@sealey.co.uk • Web: www.sealey.co.uk